

# Identify your tank conditions

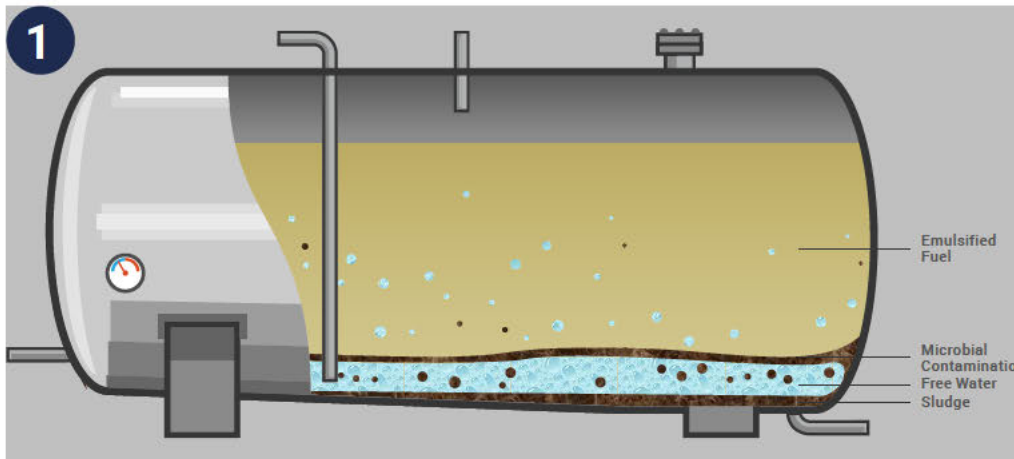

Firstly, identify the current state of the fuel and storage tank. While performing a visual inspection, if the fuel is hazy to a point where you cannot distinguish the inside of the tank, here are some options for you:

- › Take a drain or bottom sample from the fuel tank, test each sample for microbial contamination using a FUELSTAT test kit
- › Introduce the Aquafighter Dipstick Indicator into the tank to check for free or emulsified water content

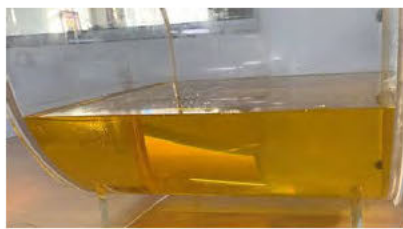

## Tank is clean and fuel is in good condition with low water content:

- › Install Aquafighter following instructions in next steps and maintain water-free conditions
- › Check periodically and replace Aquafighter when full or almost full and your tank will not suffer the fate of the next 3 examples

***This is the ideal scenario for use of Aquafighter. As always, prevention is better than cure, so look to install Aquafighter from new into clean tanks with clean fuel for long trouble-free service***

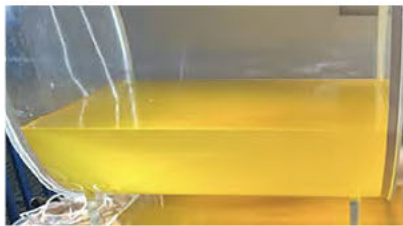

## Fuel has significant water content (high ppm):

- › Drain free water from the bottom of the tank
- › Aquafighter can then be installed to remove emulsified water
- › Aquafighter will immediately start demulsifying fuel and should be checked

after two days to determine the level of saturation

- › When the Aquafighter product (water absorbing powder) fills 50% of its chamber, replace the product with a new one to maintain water-free conditions



## Fuel and tank has some water content + sludge and microbial contamination:

- › Tank should be emptied and cleaned first to prevent this sludge and microbial growth from clogging filters and getting into machines
- › Refill with clean fuel

- › Aquafighter can be installed to remove bound/emulsified water
- › Check for levels of microbial contamination in the fuel using FUELSTAT test kit
- › It only makes sense to care for your tank so that your fuel will treat your machines well



## Fuel and tank has significant water content + heavy sludge and microbial content:

- › Whether you use Aquafighter or not, if your tank looks like this, you should not put this fuel in anything of value
- › Empty and clean this tank thoroughly and visually inspected if possible before re-use

- › Refill with clean fuel
- › Install Aquafighter and begin a new era of clean tank and clear & bright fuel
- › Check for levels of microbial contamination in the fuel using FUELSTAT test kit

## Procedure for use on vehicles, construction machinery, pleasure boats, etc

Common to fuel tanks on vehicles, construction machinery and pleasure boats is that they have an internal tank structure that includes a float and possibly a fuel pump ("feed pump"). To prevent the Aquafighter from interfering with these components or the fuel supply it is strongly recommended to remove the Aquafighter from the tank when the vehicle, machine or boat is in operation. However, it is highly recommended that the Aquafighter remains in the tank continuously outside of those operating periods, and is regularly inspected for water absorption.

### Removal during operation:

Before starting the engine of the vehicle / boat, the Aquafighter filter MUST be removed from the tank, inspected for water content (see section 7) and placed back in the airtight bag. Allow the Aquafighter to drip off excess diesel before placing it in the bag.

### Re-installation:

As soon as the vehicle / boat has ceased operation the Aquafighter should be re-installed to protect the tank and keep the fuel water free. Follow steps 2-6.

# Installation

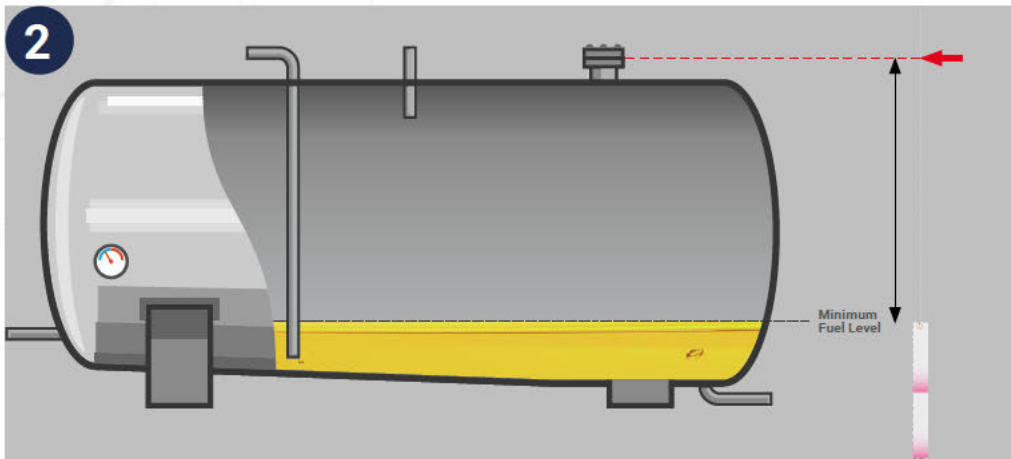

Carefully remove Aquafighter from the airtight pouch.

Measure the correct position of the Aquafighter from outside the tank and mark the cord/string length to the tank opening such that the top of the Aquafighter filter will be just below the low fuel level in the tank

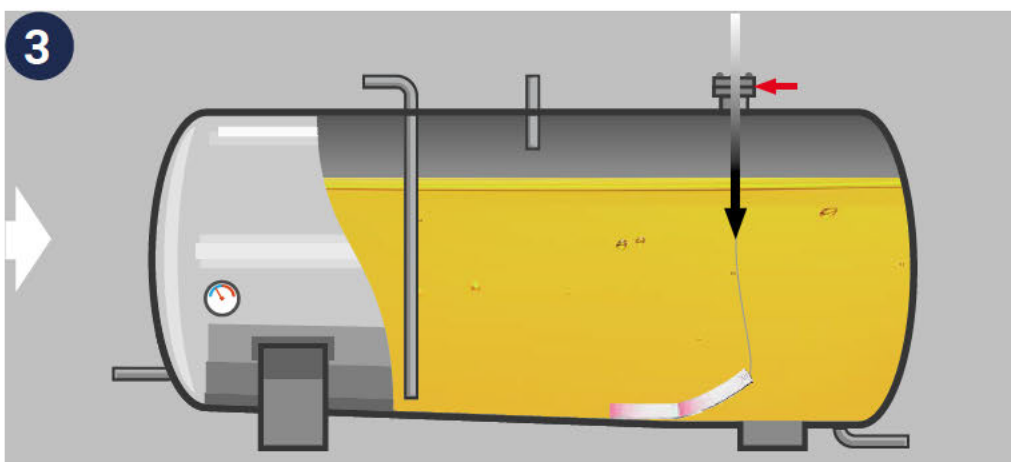

Lower the Aquafighter into the tank low point location so that the Aquafighter is resting on the bottom being lightly suspended in the tank, using the mark on the cord as reference

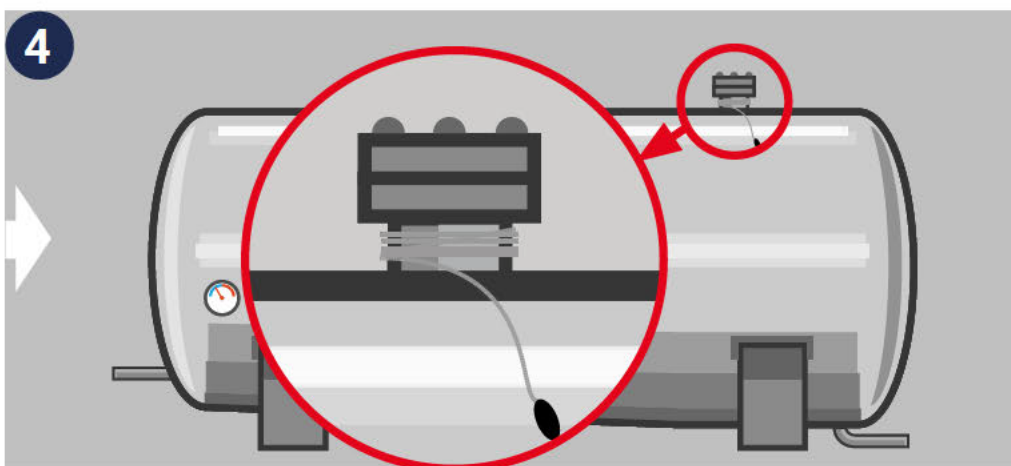

Ensure that sufficient length of cord is left outside the tank so that it can be attached, e.g. by making a loop around the filler pipe, or other suitable secure attachment

**5 Cord Attachment:**  
For suggestions of methods of attachment of cord for various tank configurations and other FAQs please see website using QR code link



**7 Inspection:**  
The Aquafighter must be inspected regularly, e.g. monthly, for water content / water absorption. If less than 50% of the Aquafighter has turned red, it can be returned to the tank. If more than 50% of the Aquafighter has turned red, replacement is recommended.

**6 IMPORTANT:**  
The pouch should be kept handy to be utilized to contain the used Aquafighter product at time of change-out.

**8 Replacement:**  
When more than 50% of the Aquafighter filter has turned red, replacement is recommended. Used Aquafighter must be safely placed in the bag it was delivered in, or similar, and disposed of at an approved collection point, e.g. the local recycling centre. The used Aquafighter filter will consist mostly of water, but small amounts of diesel can remain, and it should therefore be treated in the same way as other waste fuels, lubricating, or hydraulic oil, fuel and paint residues.

## Information

### STORAGE, STABILITY AND RECYCLING

#### Storage conditions:

No special storage conditions are specified

#### Suitable packaging:

Must only be kept in original packaging

#### Transport class:

This product does not require a classification for transport

#### Recycling:

These filters are not suitable for recycling. The used Aquafighter filter will consist mostly of water, but small amounts of diesel can remain, and it should therefore be treated in the same way as other waste fuels, lubricating, or hydraulic oil, fuel and paint residues. The user's attention is drawn to the possible existence of regional or national regulations regarding disposal of fuel

### WARNINGS AND PRECAUTIONS

- ⤵ Prior to preserving fuel with Aquafighter, it is recommended to start with a clean tank. Removal of sludge and possible microbial contamination is key to a successful fuel treatment. Microbial growth is known to clog filters and to affect equipment. Levels of microbial contamination in the fuel can be verified using a FUELSTAT test kit
- ⤵ Introduce clean fuel into a clean tank
- ⤵ Introduce the right Aquafighter product based on the fuel volume and tank configuration

### MATERIAL DATA

For complete MSDS documents please visit: [www.conidia.com](http://www.conidia.com)

#### Aquafighter® Filters:

Each filter is composed of a synthetic felt sock containing a quantity of Aquafighter powder, and a steel weight. A PPF/PA cord is attached via a Brass eyelet. The filter is supplied in a resealable PE pouch.

#### Aquafighter® Powder:

The active ingredient is a mixture of dyed polymer.

Hazardous components: No component is present at sufficient concentration to require a hazardous classification

### TROUBLESHOOTING

Problem	Cause/Remedy
Which size Aquafighter should I use?	Check the tank size opening available along with the total tank capacity Refer to table on page 1.
I have free water at the bottom of the tank, what should I do?	We recommend that you either drain or vacuum out as much free water as possible prior to installation to save you cost in replacement Aquafighters.
I have a problematic tank contaminated with dirt and bacteria build-up, what should I do?	Aquafighter will not remove large concentrations of sediments and sludge, it will not eliminate the presence of microbial growth and cannot restore already degraded diesel fuel. Clean your tank if it is dirty before use, and maintain an Aquafighter water-removal process in your tank to prevent microbial contamination and associated debris.
How do I check if my Aquafighter is saturated with water?	The best and easiest method is to simply pull up the Aquafighter from the bottom of the tank to visually inspect. Water-saturated Aquafighter powder swells and turns red. Change the Aquafighter when over half-full
How long will my Aquafighter remain active?	Under normal circumstances, and with the correct size Aquafighter product, Aquafighter can be kept in a tank for several months up 1 year, depending on Aquafighter model and tank size. However, there are situations such as badly contaminated fuel, high humidity periods or where water ingress/leaks occur that will impact the effective usage time in the tank.
How do I dispose of Aquafighter after use?	Aquafighter should be disposed of in "special waste", the same as disposal of used oil filters and other similar fuel contact products.

